



Design of a Martian Habitat, *a First Cut*

Juniper Jairala, Primary Systems Engineer

Mars or Bust, Incorporated

Space Payload Design

ASEN 5519

12-11-03

Outline

- The Mission
- The Mars Environment
- Top-Level Requirements
- Key Drivers/Design Highlights
- Design Summary
- Comparison
- Conclusions/Lessons Learned
- Future Challenges



[<http://aerospacescholars.jsc.nasa.gov>]

The Mission

- Develop Martian habitat capable of supporting humans
 - as per NASA's Design Reference Mission (DRM)

[Hoffman and Kaplan, 1997; Drake, 1998]

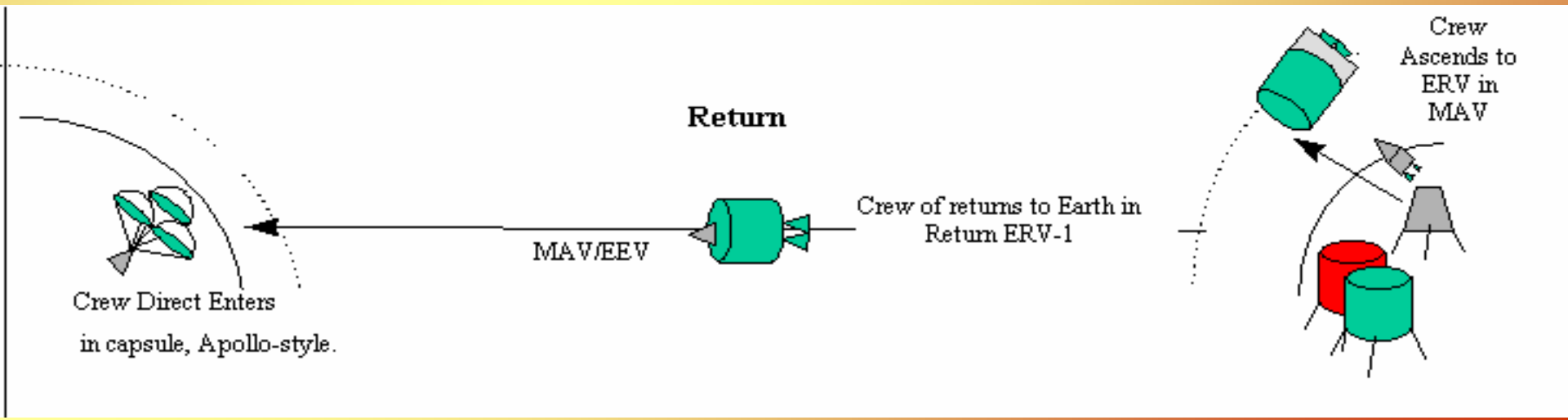



The Mars Environment



- Martian gravity $\sim 1/3$ g
- Low atmospheric pressure $\sim 1\%$ of Earth's
- Cold and dry
- High Winds
- Fine Dust
- More Radiation
- Less sunlight
- Day length \sim same as Earth



Top-Level Requirements

- Top-Level Requirements
 - 6 people, 600 days without re-supply
 - Maintain health and safety of crew
 - Minimize dependency on Earth
 - Mission critical: 2-level redundancy
 - Life critical: 3-level redundancy
 - Recommended total mass < 36,154 kg
 - Recommended total power requirement: 25 kW
- Fit within the dynamic envelope of the launch vehicle
 - Launch Shroud Diameter = 7.5 m
 - Length = 16.3 m

Key Design Drivers

- Rationalize design
- Crewed operations & automation
 - DRM
 - [Hoffman and Kaplan, 1997; Drake, 1998]*
 - Man-Systems Integration Standards (MSIS)
 - [NASA-STD-3000 rev. B, 1995]*
- Number & purpose of EVAs:
 - Hab at 10.2 psi
 - EVA protocol time considerations
- Communication delay



[<http://www.newmars.com/desert>]

Highlights - Habitat Floor Plan

ECLSS Equipment

- Above livable volume

Personal Space

- Bed
- Storage
- Desk

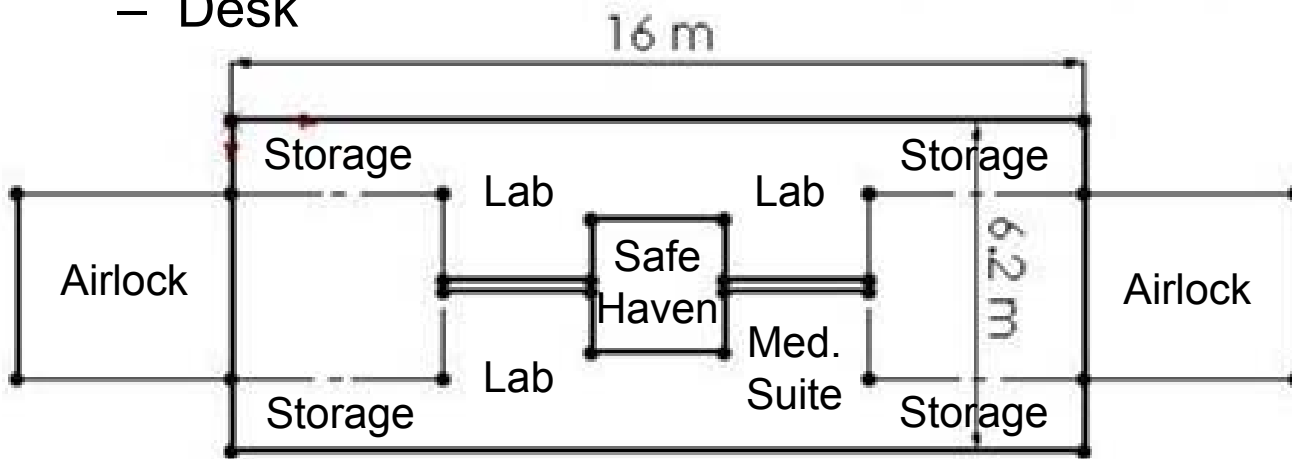
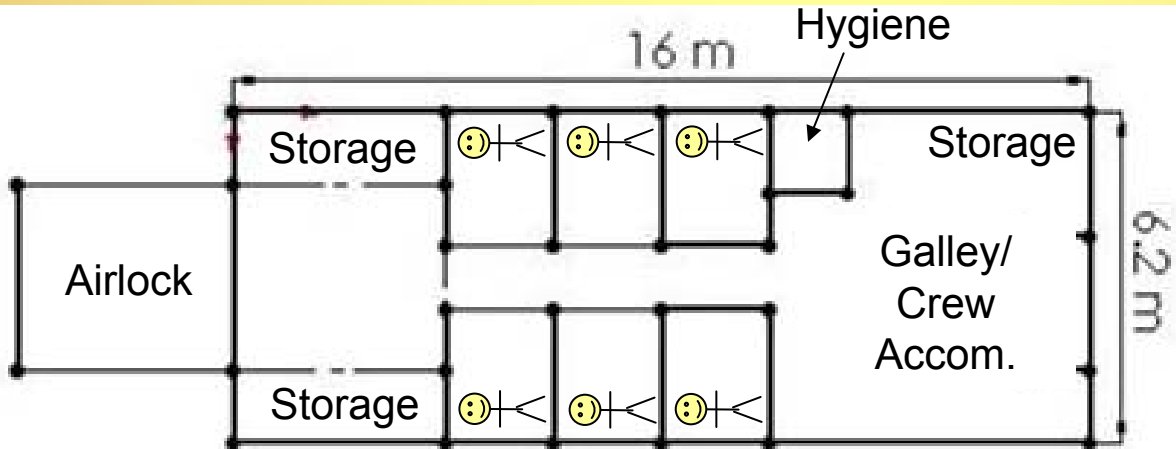

Airlock Space

- Lab
- Exercise
- Recreation

Volume = 615 m³

Usable Volume = 210 m³

Highlights: EVAS - Airlock

- Independent element capable of being relocated *[DRM]*
- Three airlocks
 - Two operational
 - One emergency/back up
- Sized for three crew members
 - Two operational EVA suits
 - One emergency/back up EVA suit
- Airlock will be a solid shell

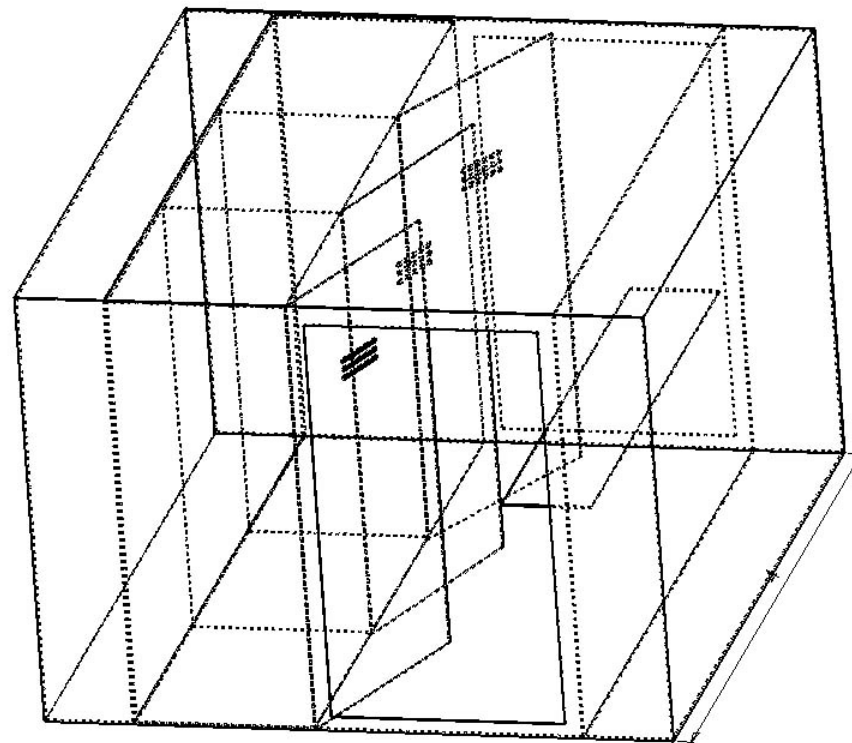

Conceptual Drawing

Human Inputs and Outputs

O₂ 0.636 – 1 kg/p/d

Potable H₂O
2.27 – 3.63 kg/p/d

Food (dehydrated)
0.5 – 0.863 kg/p/d
(2200 kCal/p/d)

Hygiene H₂O
1.36 – 9 kg/p/d

N₂

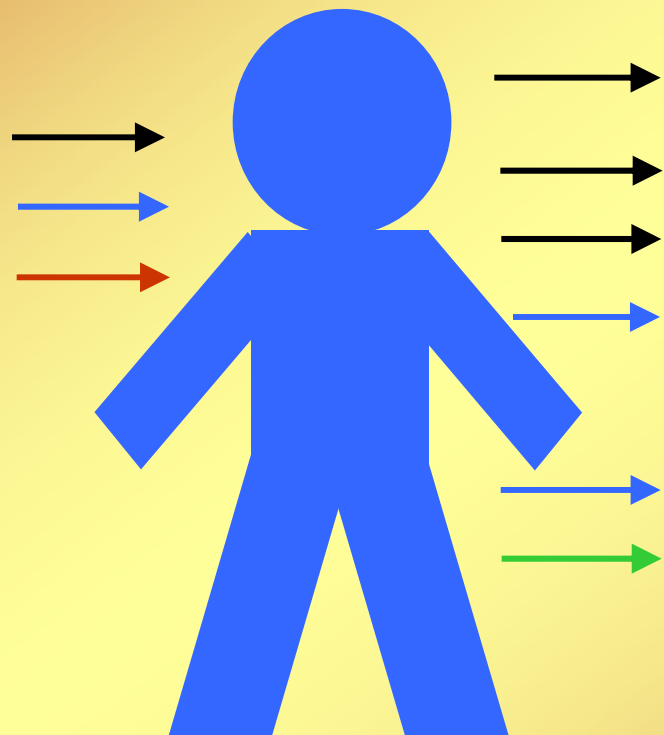

Heat 0.1 kW/p/d

CO₂ 0.726 – 1.226 kg/p/d

Respired & Perspired H₂O 2.28 kg/p/d

Sweat Solids 0.02 kg/p/d

Urine (solid & liquid) 1.27 – 2.27 kg/p/d

Feces (solids & liquids) 0.12 kg/p/d

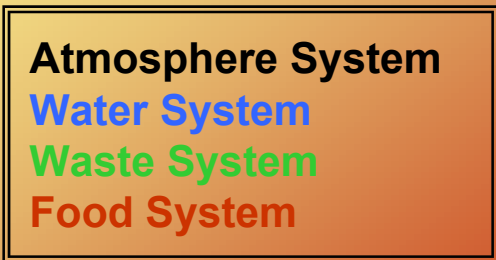

Life Support System

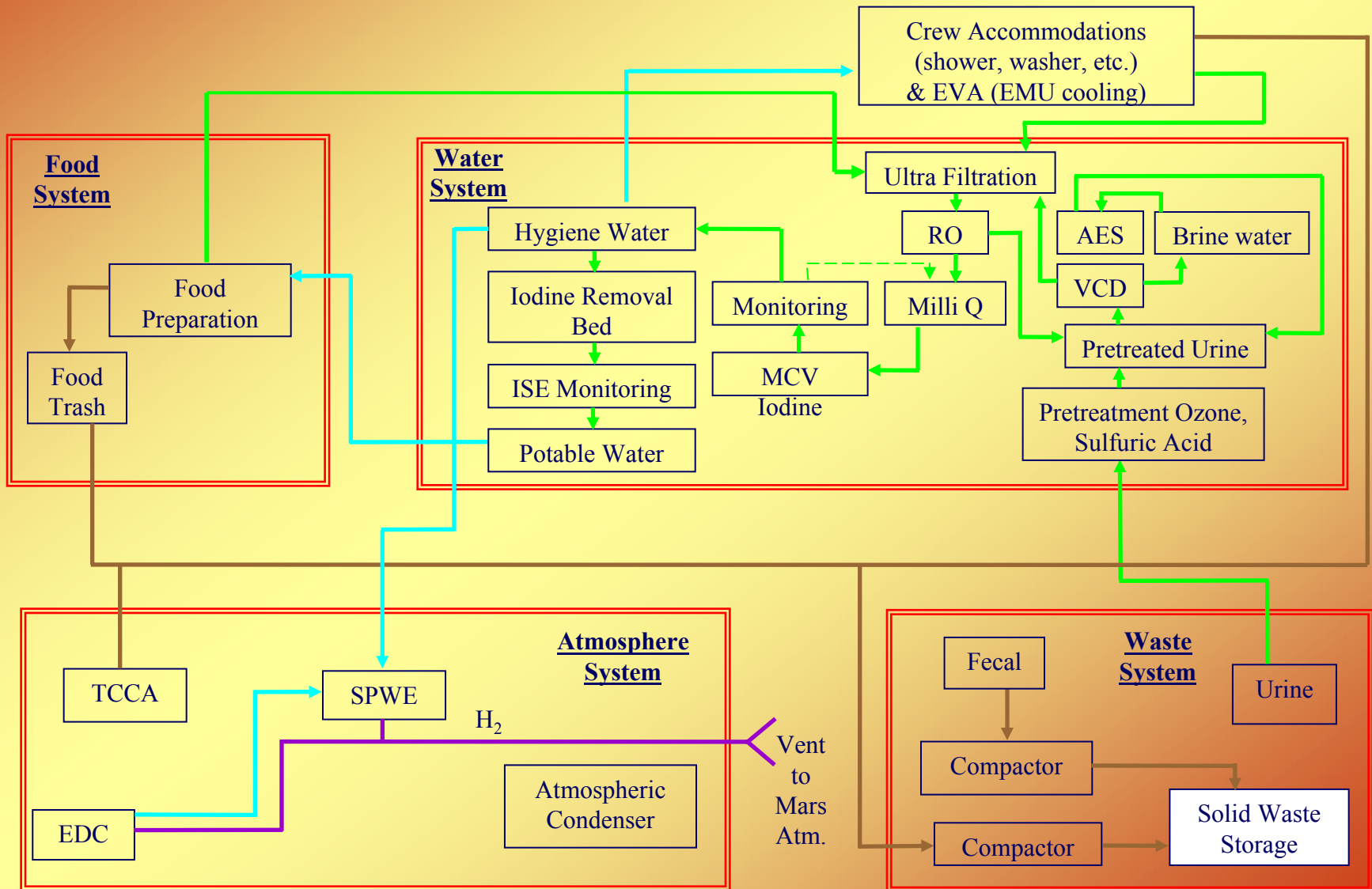



Waste Handling

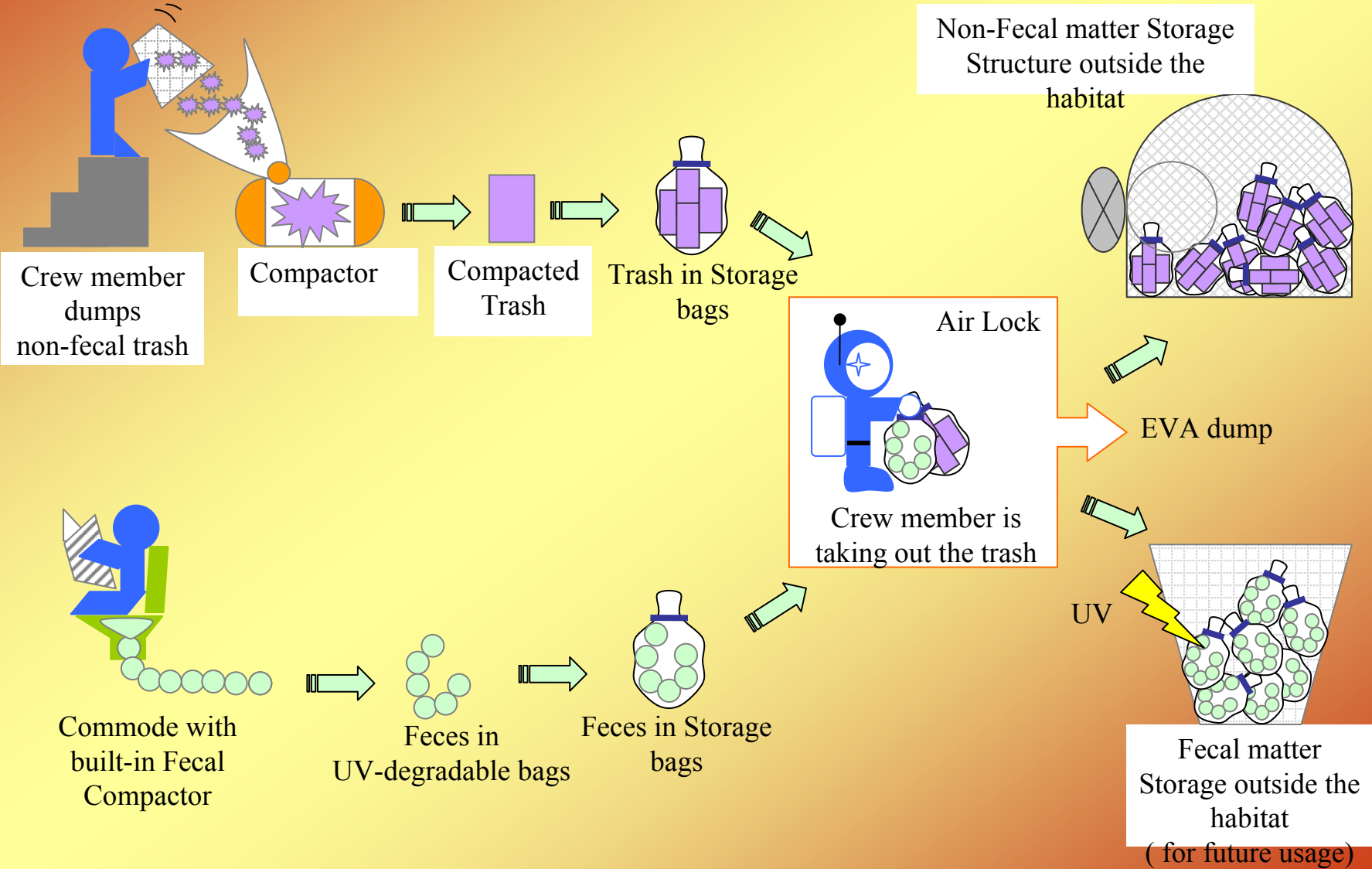

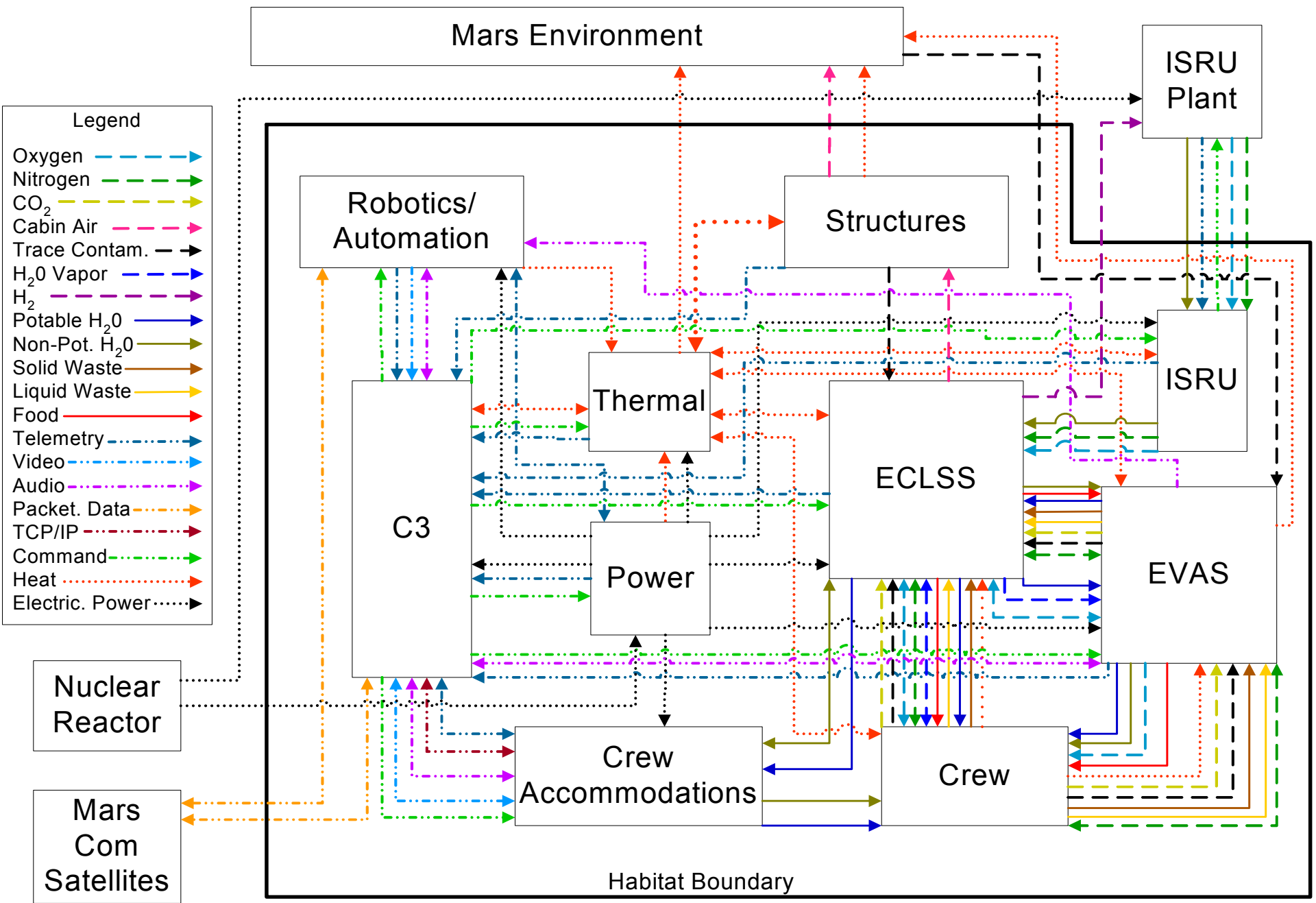

MOB Habitat Overall Subsystem Functional Diagram

Architectural Overview

- Horizontal Orientation
 - Stability
 - Expansion
 - Emergency exit
- Challenges
 - Landing/setup
 - Center of mass
 - Using volume efficiently

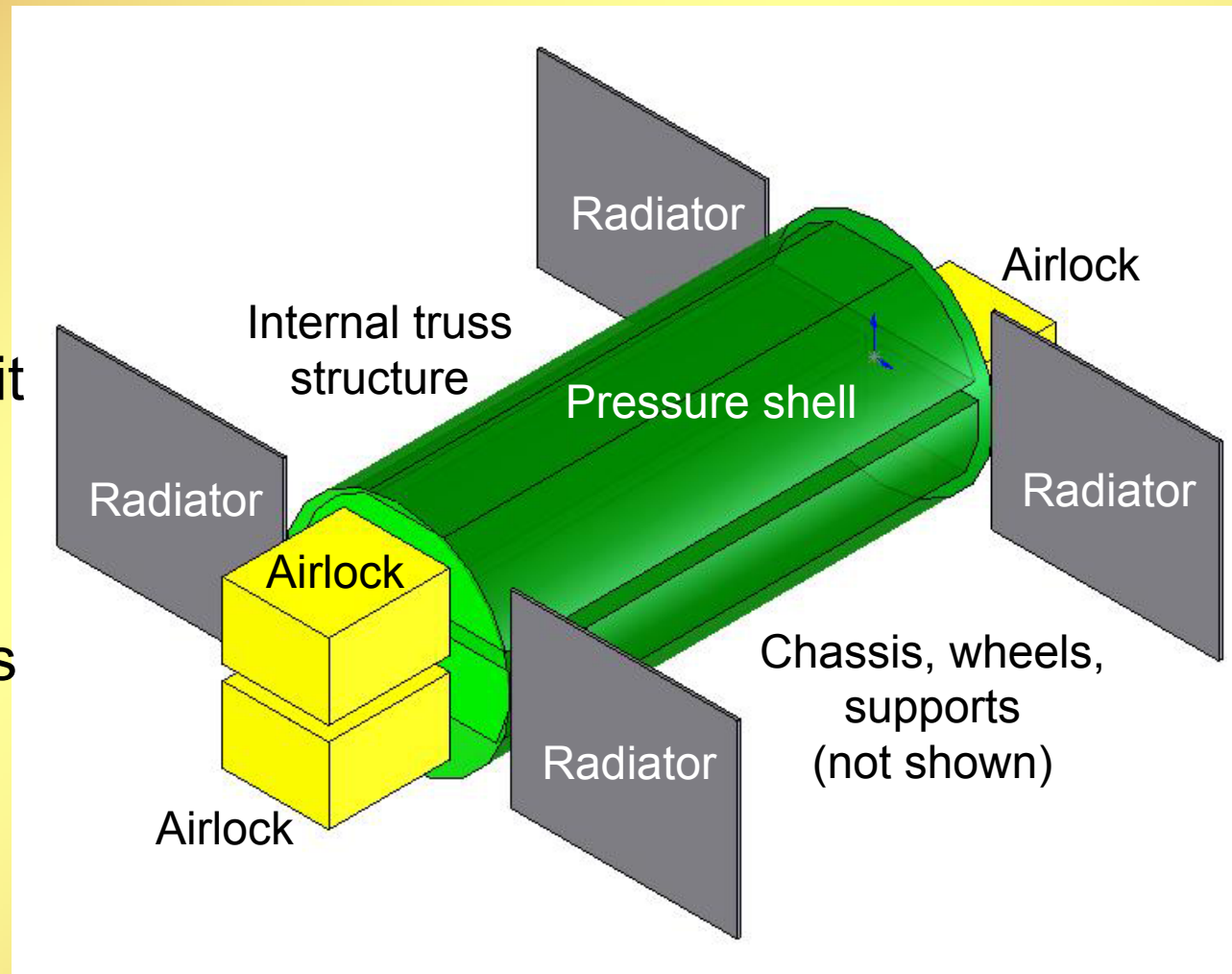



Design Summary



- Mass 67,910 kg**
 - Exceeds DRM recommendation by 31,756 kg
 - Exceeds max allowable by ~17,910 kg
- Overall Volume 615 m³**
 - Meets DRM max allowable
- Subsystem Volume 405 m³**
 - 210 m³ of open space in habitat
- Maximum Power 42.6 kW**
 - Exceeds DRM recommendation by 17.6 kW
 - Overall Martian base power = 160 kW

Subsystem	Total Mass (kg)	DRM mass (kg)	Total Power (kW)	Total Vol. (m ³)
ISRU	330		0.5	0.7
Structures	21000	20744	N/A	150.0
Power	2000	3250	11.3	4.1
ECLSS	31200	4661	9.6	84.0
Thermal Control	5000	550	2.0	14.0
MO/CA	6000	5000	11.8	46.0
C ³	530	320	1.9	0.3
Robotics/Auto.	880		0.5	0.6
EVAs	970	1629	5.0	105.0
Grand Totals	67910	36154	42.6	405



Other Designs



Mars or Bust

ESA Aurora*

Subsystem	Total Mass (kg)	Total Power (kW)	Total Volume (m3)
ISRU	330	0.5	0.7
Structures	21000	N/A	150.0
Power	2000	11.3	4.1
ECLSS	31200	9.6	84.0
Thermal Control	5000	2.0	14.0
Mission Ops/Crew Accom	6000	11.8	46.0
C ³	530	1.9	0.3
Robotics/Automation	880	0.5	0.6
EVAs	970	5.0	105.0
Grand Totals	67910	42.6	405

Subsystem	Total Mass (kg)	Total Power (kW)	Total Volume (m3)
(ISRU)	unavail.	0.50	unavail.
Habitat Module	25293	N/A	unavail.
Power	5782		unavail.
Life Support	10862	9.56	unavail.
(Thermal Control)	unavail.	2.00	unavail.
Human Factors	5038	11.75	unavail.
Comm/Data Management	546	1.90	unavail.
(Robotics/Automation)	unavail.	0.53	unavail.
EVA	859		unavail.
10% Margin (Mass)	4838	N/A	N/A
20% Margin (Power)	N/A	5.25	N/A
Grand Totals	53216	31.49	441.70

*[Fisackerly et al., 2003]

Mars or Bust

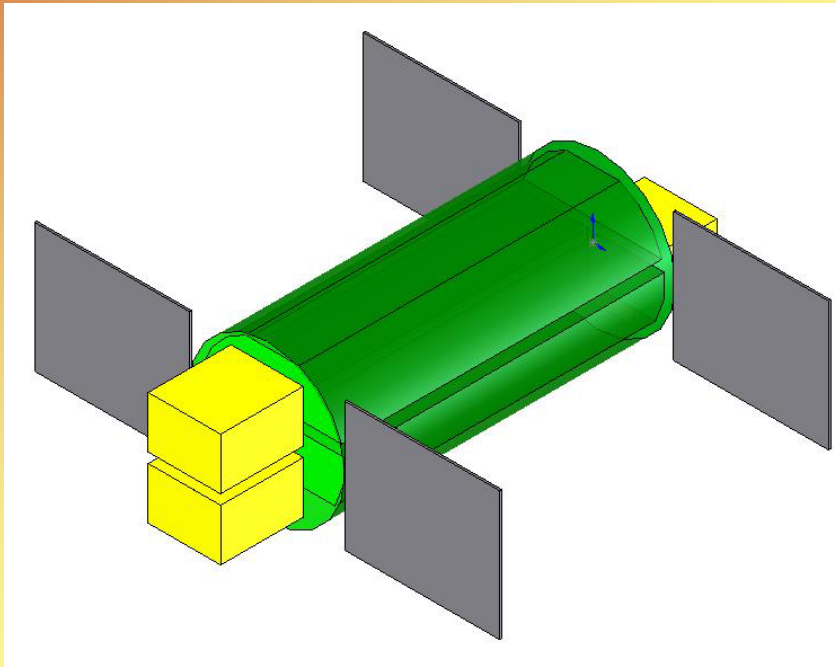

(Not to scale)

ESA Aurora*

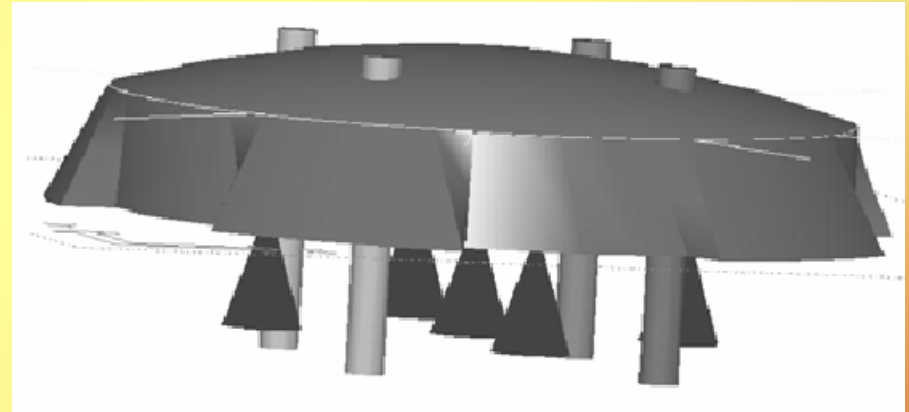

**[Fisackerly et al., 2003]*



Conclusions & Lessons Learned



- A lot more work to do! Optimization, redundancy, reliability
- Multiple roles helpful (min. 2 subsystems/team member)
- Organizational architecture of MOB not optimal
 - Should develop more driving subsystems first (ECLSS, Structures, EVAS Interfaces)
 - Then disperse resources to others (C³, Power, ...)
- Main Design Drivers:
 - Mission Operations
 - EVAS Interfaces
 - ECLSS consumables
- Huge, multi-disciplinary undertaking
 - systems engineering
 - architecture
 - human factors



Future Challenges



- Radiator/heat rejection design
- 2nd story airlock – transport, interface with rover
- Lifting capability of rover
- Landing/setup (rotation vertical → horizontal)
- Horizontal vs. vertical orientation – trade study
- Reduce consumables mass
- Communication with Earth (DSN over-subscribed)

[<http://deepspace.jpl.nasa.gov/dsn/faq-dsnops.html>]



References

- Eckart, Peter. Spaceflight Life Support and Biospherics, Kluwer Academic Publishers, Boston, MA; Microcosm Press, Torrance, CA, 1996.
- Fisackerly, et al. Cranfield Aurora: Mars Excursion Module. ESA Aurora Student Design Project. Cranfield University, United Kingdom 2003.
- Hoffman, Stephen J. and Kaplan, David L. Human Exploration of Mars: The Reference Mission of the NASA Mars Exploration Study Team. Lyndon B. Johnson Space Center, Houston, TX July 1998.
- Larson, Wiley J. and Linda K. Pranke Human Spaceflight: Mission Analysis and Design. The McGraw-Hill Companies, Inc, New York 2000.
- Man-Systems Integration Standards, NASA-STD-3000, rev. B, 1995. http://msis.jsc.nasa.gov/MSIS_home.asp

Other websites:

- [\[http://www.newmars.com/desert\]](http://www.newmars.com/desert)
- [\[http://aerospacescholars.jsc.nasa.gov\]](http://aerospacescholars.jsc.nasa.gov)
- [\[http://deepspace.jpl.nasa.gov/dsn/faq-dsnops.html\]](http://deepspace.jpl.nasa.gov/dsn/faq-dsnops.html)
- <http://www.colorado.edu/ASEN/project/mob>



Report Available
December 17, 2003

<http://www.colorado.edu/ASEN/project/mob>